

XTREME SHELL™

US Patent 9,279,532 / CA Patent 2,877,313

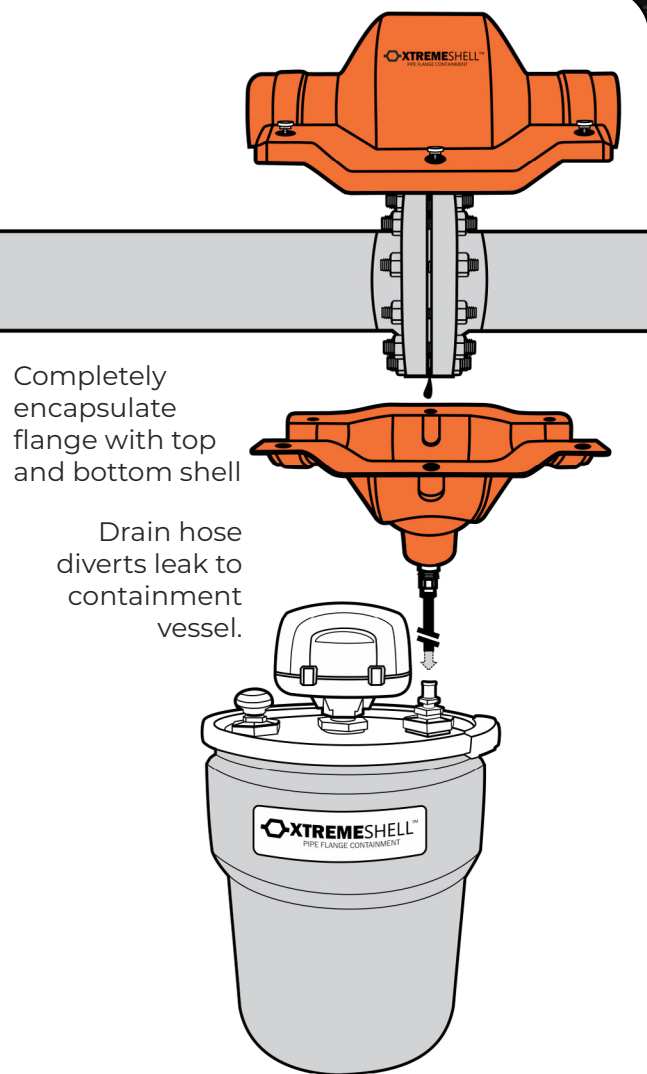

The Xtreme Shell™ (XS) is a two-piece, hard containment shell designed to fully enclose your flange, manifold or any other leak point. A drain hose attaches to the bottom of the shell and connects to a secondary containment vessel.



FEATURES

- 100% Reusable
- Immediate to long-term solution
- Add-on Remote Monitoring System available

The XS has been honored with the following New Product of the Year Awards:



XTREME SHELL™

US Patent 9,279,532 / CA Patent 2,877,313

SPECIFICATIONS

- Designed for Class 150 Pipe and Flange
- Impact resistant up to -20° F
- Handles fluids up to 200° F
- Flame resistant - UL 94 V-O
- 1/2 in. Dia x 16 ft. drain hose
- 10-gallon containment vessel



ADD REMOTE MONITORING

FLUID MONITORING HAS NEVER BEEN EASIER

Add Remote Fluid Monitoring to your XS for an all-in-one, cellular-enabled monitoring solution that provides instant fluid level alerts and notifications via text and email.

- Easy installation
- Allows for scheduled maintenance
- Check levels remotely, reduce transportation costs
- Accurate tank data
- Battery powered



THE ONLINE INFORMATION PORTAL

Remote monitoring provides quantifiable flow rate metrics, allowing you to make intelligent decisions regarding on-site leak management.

All data is collected across our cloud-based platform keeping you informed with accurate fluid level readings on containment tanks.

Follow this link to view a video of the XS in action.

